

LAND  PORT

GUIDE

**INSIDE FRONT COVER
(THIS TYPE DOES NOT PRINT)**

LANDPORT

Thank you for purchasing a Landport,™ the container for what life brings you. We hope you love this charming delivery lockbox as much as we do.

Sincerely,
The Landport Team



TABLE OF CONTENTS INSTALLATION

What You'll Find in the Landport.....	Pg. 1
Landport Dimensions: Deluxe Rectangle Cube.....	Pg. 2
Placement Considerations.....	Pg. 3
Choose Number of Anchors to Use.....	Pg. 4
Safety Considerations.....	Pg. 4
Installation Methods.....	Pg. 5-10
Landport Care.....	Pg. 10
Touch-up Paint.....	Pg. 10



TABLE OF CONTENTS USER GUIDE

Using the Keypad.....	Pg. 11
Battery Installation.....	Pg. 11-12
Locking Your Landport.....	Pg. 11
Unlocking Your Landport.....	Pg. 11
Operating & Programming the Keypad.....	Pg. 13-14
Changing the Administrator Code.....	Pg. 15-16
Setting the Access Codes.....	Pg. 15-16
Assigning Codes to Keypad Positions.....	Pg. 17-18
Setting the Administrator Code Algorithm.....	Pg. 19-20
Setting the Access Codes Algorithm.....	Pg. 21-22
Deactivation Security Feature.....	Pg. 23
Low Battery Indicator.....	Pg. 23
Contact Us.....	Pg. 23
Warranty.....	Pg. 23
Keypad Codes Card.....	Pg. 24
Key Replacement.....	Pg. 25

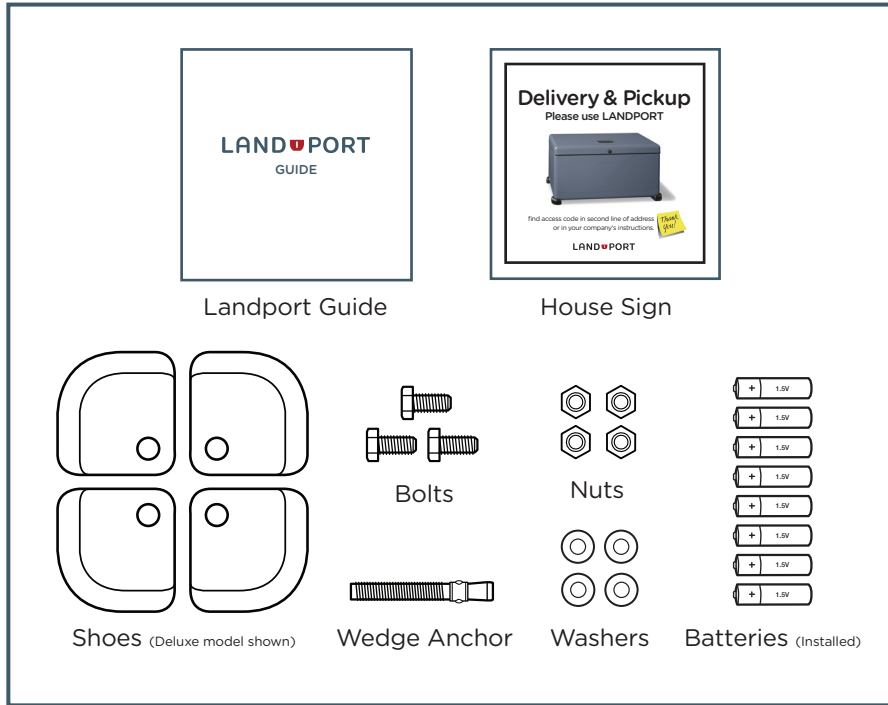
WHAT YOU'LL FIND IN THE LANDPORT



LANDPORT DIMENSIONS & WEIGHT: DELUXE | RECTANGLE | CUBE

Model	Dimensions	Approx. Weight
 <p>Deluxe</p>	34" x 17" x 17"	50 lbs.
 <p>Essentials Rectangle</p>	34" x 17" x 17"	50 lbs.
 <p>Essentials Cube</p>	17" x 17" x 17"	35 lbs.

PLACEMENT CONSIDERATIONS

A few things to consider when deciding where to install your Landport:

1. Landport will function best on a stable, firm and level surface that has good drainage.
2. Landport should be readily accessible to delivery personnel and other users.
3. Do not place Landport where its lid will be obstructed (such as under a branch), or where you can't open the lid completely (such as too close to a wall). We recommend a distance of 4" measured from the back of the Landport to the wall behind it. (Fig. 1)
4. Avoid installing Landport where water or snow may accumulate.
5. You may want to give some thought to the amount and intensity of sun exposure your Landport will receive throughout the year. Landport's steel body can heat up and become hot to the touch if left in direct sunlight. Also, a darker colored Landport like brown or black will absorb more heat.

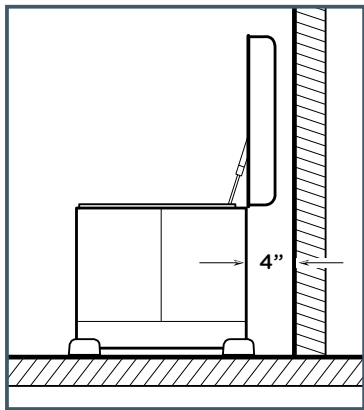

Fig. 1

CHOOSE NUMBER OF ANCHORS TO USE

You have the option to anchor Landport at 1, 2, 3 or all 4 points. We have included one anchor for you, but the decision is up to you. More anchors mean more security. The shoes hide the bolts, so it won't be obvious where or how your Landport is anchored to the surface.

Note: If you decide to get more anchors, purchase 3/8" diameter, 3" long stainless steel wedge anchors. Using stainless steel prevents rust.

SAFETY CONSIDERATIONS

Please read and follow all safety instructions when using power equipment. We strongly recommend using protective eyewear and earplugs when using the hammer drill.

INSTALLATION METHODS

If you are not comfortable installing Landport yourself, we suggest you seek a contractor or an experienced handy person to do the job. For such a professional, installing Landport should be a quick and easy process.

SECURING LANDPORT TO EXISTING CONCRETE

The following installation procedure applies to existing concrete driveways, walkways, porches or patios. Expect to drill into the material and insert anchors.

WHAT YOU'LL NEED

- Roto hammer or hammer drill, which can be found at Home Depot tool rental or similar tool rental outlets.
- 3/8" masonry drill bit - carbide is recommended.
- 1 or more 3/8" diameter stainless steel concrete wedge anchors 3" in length.
- A hammer.
- A 9/16" combination wrench, adjustable wrench or 9/16" socket wrench.
- Chalk, marker, crayon, pencil - anything that can be used to mark the concrete for drilling.

Note: Landport anchor hole is 1/2"; we recommend 3/8" diameter bolts.

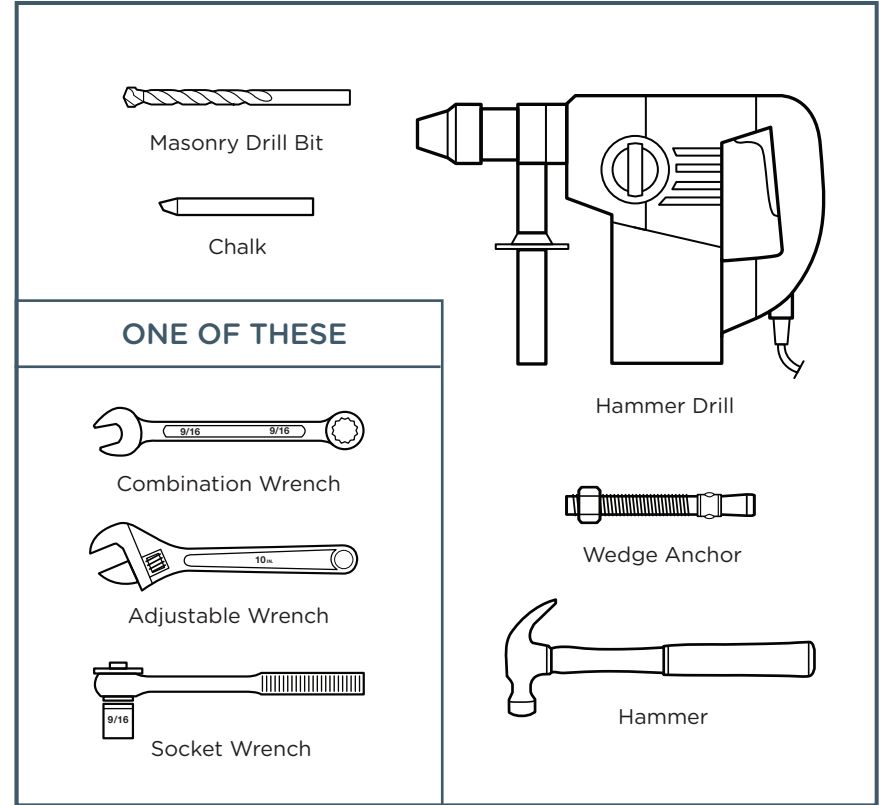

INSTALLING THE WEDGE ANCHORS

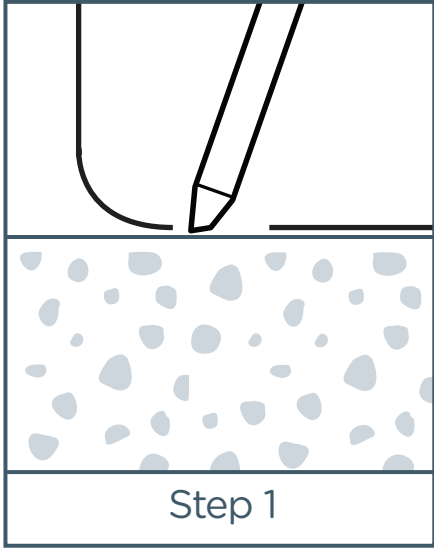

Step 1

1. Position your Landport where you want it.
2. Mark the holes with chalk or other marker.
3. Move Landport out of the way.

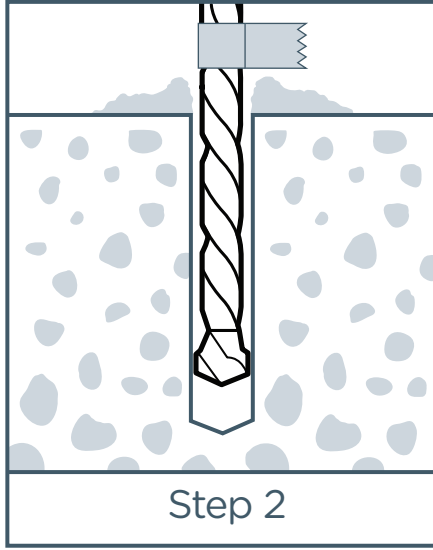

Step 2

1. Wrap a bit of visible tape around the drill bit at 3 1/4" - then you'll know when to stop drilling.
2. Drill a 3 1/4" deep hole into the concrete using a 3/8" bit, drilling 1/4" more than the length of the anchor.
3. Clean the concrete dust out of the hole with a vacuum.

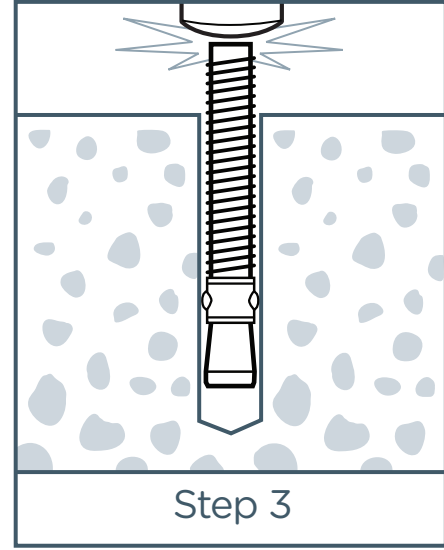

Step 3

1. Remove the nut and the washer from the wedge anchor.
2. Hammer the wedge anchor bolt into the hole. The threaded part of the bolt should be up, such that the wedge is in the bottom of the hole.

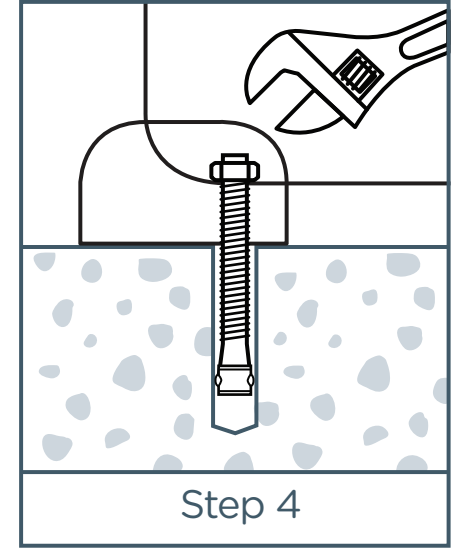

Step 4

1. Place the shoe over the wedge anchor bolt and position the Landport over the shoe and the bolt.
2. Attach the washer and the nut to the anchor bolt from inside the Landport.
3. Tighten the nut 2 - 3 complete turns. This will cause the wedge to expand and anchor into the concrete.

SECURING LANDPORT TO A WOOD PORCH OR DECK

If you can access the underside of your wood porch or deck, use nuts and bolts.

If you can't access the underside of the wood porch or deck, you can secure your Landport with 3/8" x 3" lag bolts. Drill a 5/16" pilot hole first. (Fig. 2)

Note: We recommend using stainless steel hardware to prevent rusting.

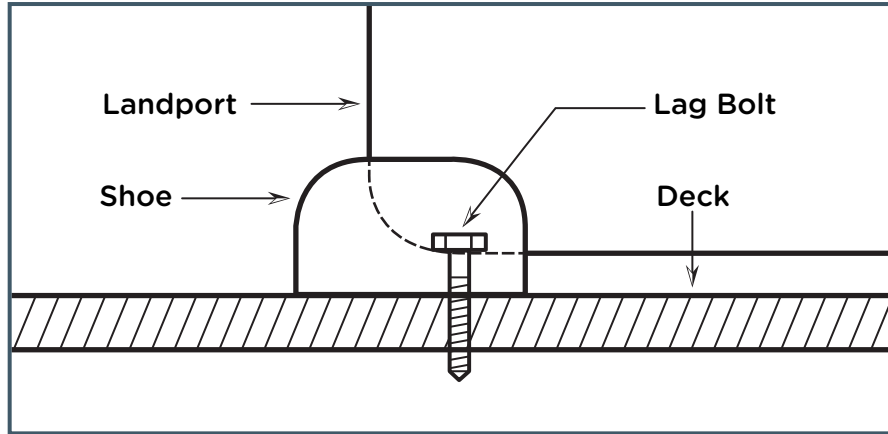

Fig. 2

OTHER INSTALLATION OPTIONS:

If the installation methods described aren't possible, you can also:

1. Secure Landport to a concrete footing using a threaded rod.
2. Pour a new concrete slab and secure using a threaded rod.

LANDPORT CARE

To clean Landport use a soft cloth, water and a nonabrasive mild detergent cleanser, such as dish washing liquid or car washing detergent. Do not use solvents such as paint thinner, acetone or nail polish remover, which may dull the finish.

TOUCH-UP PAINT

- Black - RAL* 9005
- Blue Gray - RAL 7031
- Cream - RAL 9010
- Red - RAL 3013
- Brown Black - RAL 8022

*RAL is a color matching standard for powder coating.

If Landport gets scratched, we recommend applying oil on the scratch to temporarily delay rusting.

We also recommend touching up the scratch with the appropriate paint as soon as possible. Please see Parts & Accessories at www.theLandport.com for information on ordering touch up paint.

USING THE KEYPAD

Prior to using the keypad please install the batteries.

BATTERY INSTALLATION

1. Remove battery enclosure cover by lifting up the finger-hold indentation. (Fig.3)
2. Install 8 AA alkaline batteries as shown and replace cover. (Fig. 4)
3. Make sure the battery enclosure ON/OFF switch is in the ON position.

LOCKING YOUR LANDPORT

To lock Landport simply close the lid - the lock automatically engages.

UNLOCKING YOUR LANDPORT

To unlock Landport use the key or the keypad.

The keys can be used for regular operation of your Landport or as an override in case of a forgotten Access Code.

Please do not store your keys in the Landport.

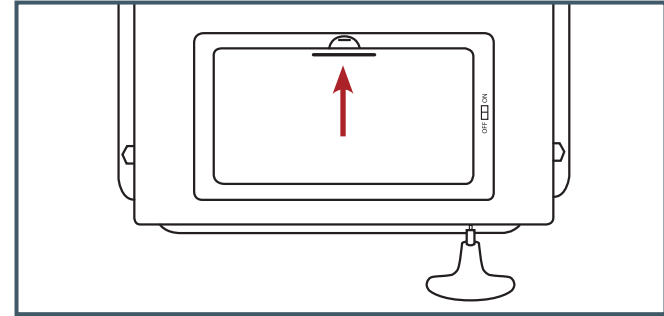

Fig. 3

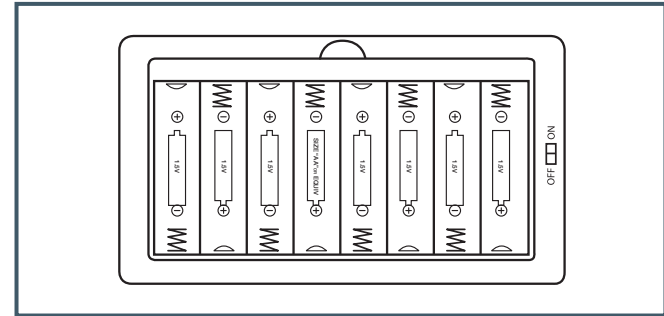

Fig. 4

OPERATING & PROGRAMMING THE KEYPAD

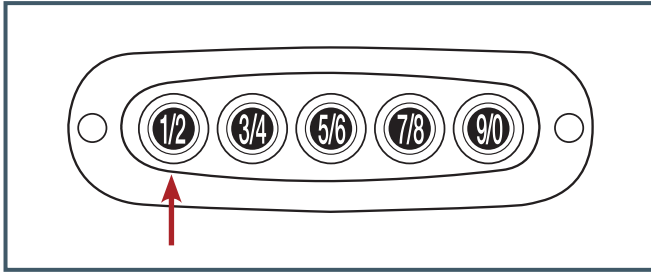

Fig. 5

NOTE: The 2 numbers on each key represent a choice. For example 1/2 means 1 or 2. Thus the keypad has 5 distinct keys. A code of 1-3-5-7-9 is the same as 2-4-6-8-0. This is the same convention used by automobile manufacturers. (Fig.5)

The Keypad has 2 modes:

1. Operating Mode – regular use
2. Programming Mode – setting Administrator and Access Codes

The Keypad has 2 types of codes:

1. Administrator Code (one)
2. Access Code (up to five)

OPERATING MODE

When you press the buttons in Operating Mode, you will hear 1 beep for each button press.

When the correct Access Code is entered, you will hear the keypad make 2 short beeps and the latch will release to unlock the Landport.

PROGRAMMING MODE

When you press the buttons in Programming Mode, you will hear 2 beeps for each button press.

Programming mode enables the Administrator (that's you!) to set Access Codes.

You are the keeper of the keys or, in this case, the keypad Access Codes. You can assign up to 5 different Access Codes for other people, such as delivery personnel, friends and neighbors, and reset these codes as needed. The Administrator Code is the master code that allows you to set Access Codes.

NOTE: All Landports come with the preset Administrator Code of 7-7-7-7-7 and a preset Access Code of 1-3-5-7-9. Please change these codes prior to use or the items in the Landport will not be secure.

CHANGING THE ADMINISTRATOR CODE

IMPORTANT: Changing the Administrator Code resets all Access Codes.

The black square button at the bottom of the black metal enclosure is the button to start setting the Administrator Code sequence. (Fig. 6)

[See: Setting the Administrator Code Pg. 19-20]

PROGRAMMING THE ACCESS CODES

The center button in the keypad is the button used to start setting the Access Codes sequence. (Fig. 7)

[See: Setting the Access Codes Pg. 21-22]

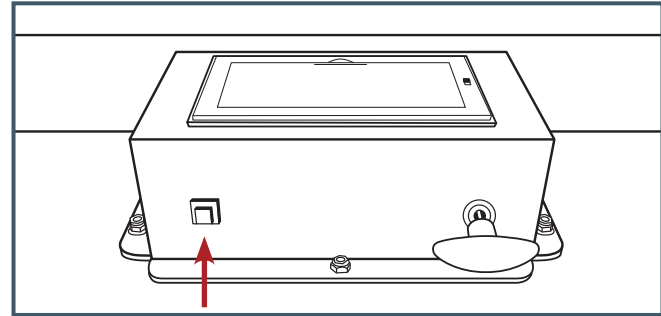

Fig. 6

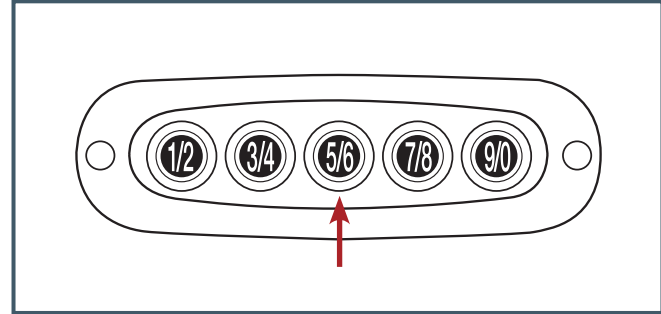

Fig. 7

ASSIGNING CODES TO KEYPAD POSITIONS

IMPORTANT: Codes are assigned to positions. (Fig. 8)

1/2 = Position 1 - an Access Code and an Administrator Code

3/4 = Position 2 - an Access Code

5/6 = Position 3 - an Access Code

7/8 = Position 4 - an Access Code

9/0 = Position 5 - an Access Code

The Administrator Code is assigned to Position 1.

The Access Codes are assigned to Positions 1, 2, 3, 4, 5.

Changing the Administrator Code will erase all previously set Access Codes in Positions 1, 2, 3, 4, 5.

You can assign up to 5 different Access Codes. As additional Access Codes are assigned, existing Access Codes are overwritten.

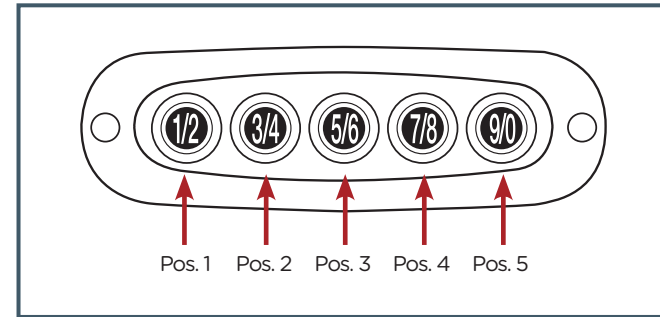
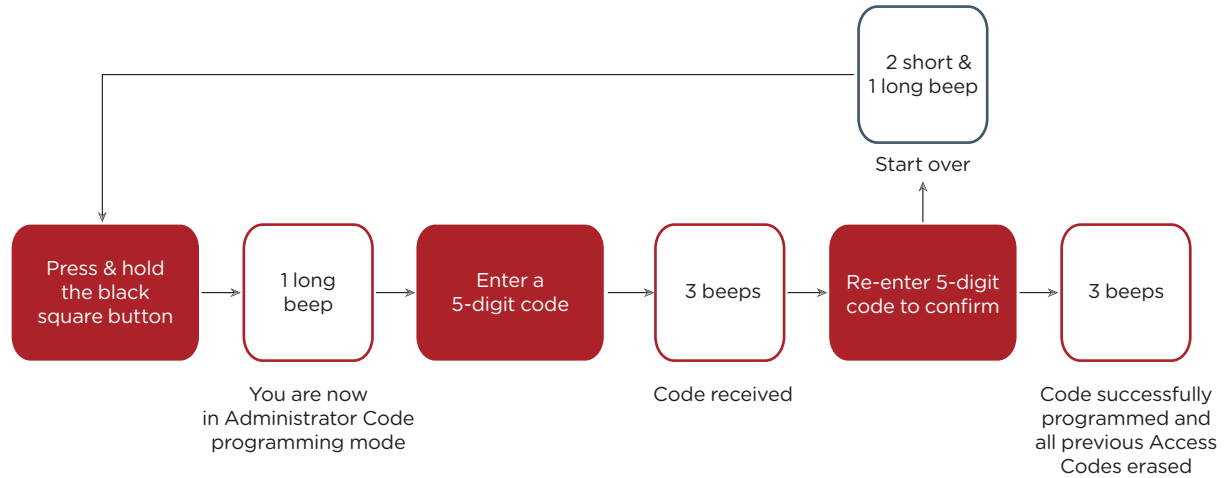
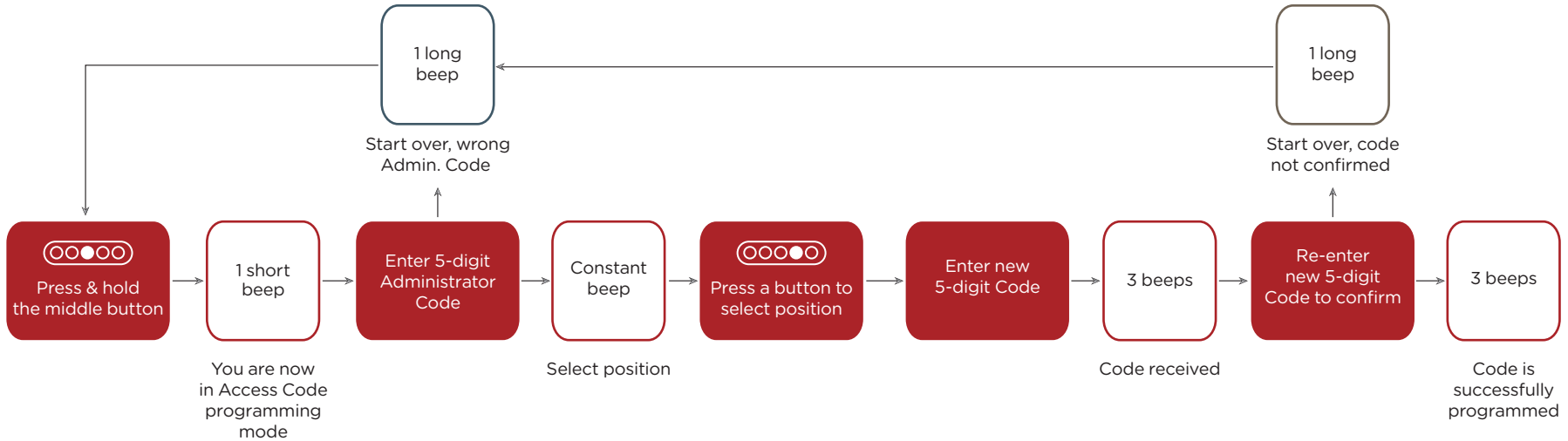

Fig. 8

SETTING THE ADMINISTRATOR CODE



SETTING THE ACCESS CODES



DEACTIVATION SECURITY FEATURE

After repeated entering of incorrect codes (20 button presses without enabling the system), the keypad is deactivated for 1 minute. This helps prevent unauthorized access with random codes. While the keypad is deactivated, no beeps will sound.

LOW BATTERY INDICATOR

The keypad normally runs on 12 volts. When the keypad is at a voltage level of 9.0V or less, the keypad provides a short beep 0.5 seconds after unlocking. This indicates that it's time to replace the batteries.

CONTACT US

Website: www.thelandport.com **Email:** info@thelandport.com

Phone: 971.258.1970 **Hours:** Monday-Friday, 8am-5pm (PST)

WARRANTY

We sincerely want you to be happy with your purchase, and will work with you in good faith through any reasonable and unforeseen issues that affect your Landport. The metal structure itself, including the steel and brackets, is guaranteed for 10 years. Other components are guaranteed for 1 year.

LANDPORT

ADMINISTRATOR CODE

— — — — —

ACCESS CODES

- ① — — — — —
- ② — — — — —
- ③ — — — — —
- ④ — — — — —
- ⑤ — — — — —

The Codes can be changed at any time. See your Landport Guide.

KEY REPLACEMENT

We strongly suggest you take the following steps before your keys are misplaced:

1. Locate the 4-digit number inscribed on your key. (Fig. 9)
2. Write down your key number here:

3. Keep this information in a safe place where you can easily find at a later date.

In the event that you do misplace the keys to your Landport, we can send you a replacement set for a minimal fee plus shipping. For more information, visit www.thelandport.com and click on Parts and Accessories.

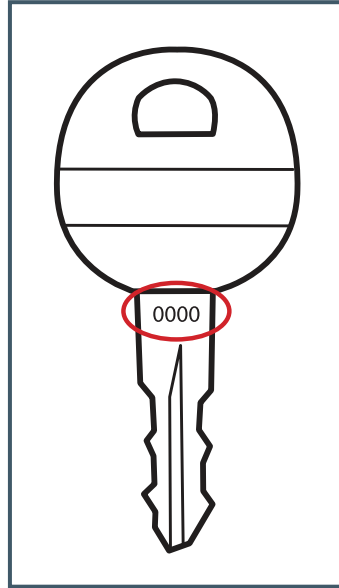

Fig. 9

**INSIDE COVER
(THIS TYPE DOES NOT PRINT)**

BACK COVER
(THIS TYPE DOES NOT PRINT)